

| NO. | NAME | MATERIAL | WEIGHT (G) | MATERIAL |
|-----|-----------------|-----------|------------|----------|
| 1 | Outer Jar | PMMA | 94±2g | |
| 2 | Mask | PP | 4±0.5g | |
| 3 | Inner container | PP | 3.8±0.5g | |
| 4 | Liner | PE | 1.2±0.3g | |
| 5 | Disc | PVDC | | |
| 6 | Inner Cap | ABS | 8.6±0.5g | |
| 7 | Outer Cap | Aluminium | | |
| 8 | Plate | Aluminium | | |
| 9 | Top Plate | PMMA | 7±0.5g | |

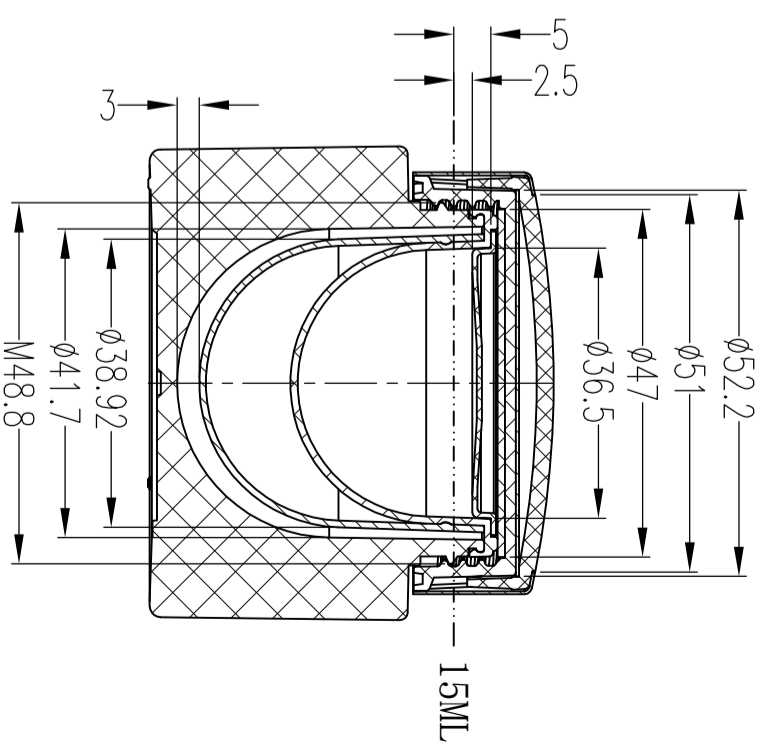

PJ2020005-15ml

| NO. | REVISID RECORD | SIGNATURE | DATE | UNIT | SCALE | VIEW | CUSTOMER | PRODUCT | MATERIAL |
|-----|----------------|-----------|------|----------|---------|-------|-------------------------------------|---------------|----------|
| | | | | mm | 1:1 | YJW | ZHEJIANG RUICHANG INDUSTRY CO.,LTD. | 15g Cream Jar | |
| | | | | APPROVED | CHECKED | DRAWN | | PART NAME | WEIGHT |
| | | | | | | | | DRAWING NO. | PAGE |
| | | | | | | | | | 10/10 |

THE SIZES WITH * CAN BE ADJUSTABLE FOR FUNCTION

