

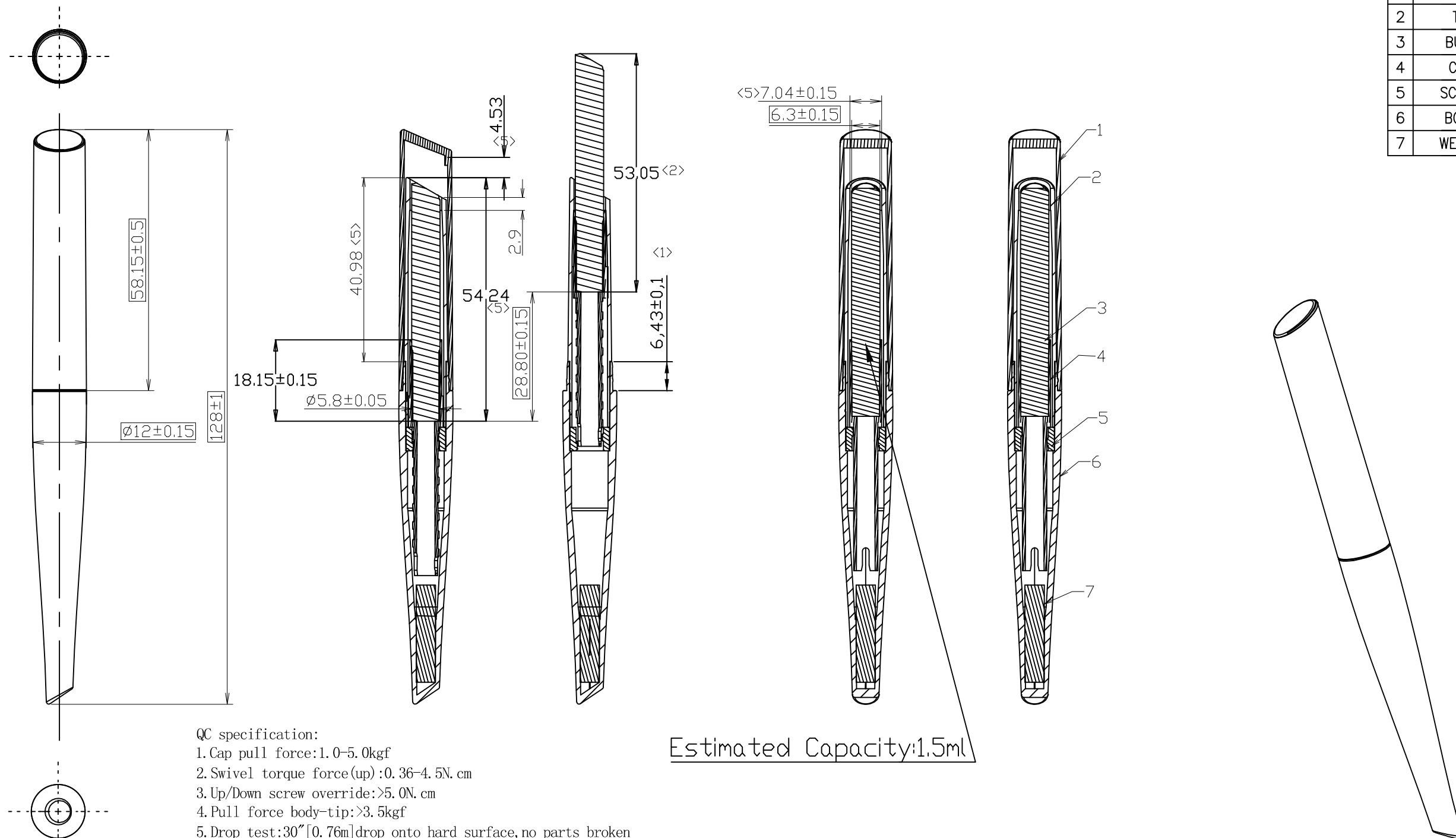

No.	NAME	Material	weight
1	CAP	ABS	2.1g
2	TIP	ABS	1.0g
3	BULK	---	---
4	CUP	POM-LF/POK	2.0g
5	SCREW	POM-LF/POK	0.3g
6	BODY	ABS	2.6g
7	WEIGHT	FE	2.4g



- QC specification:
1. Cap pull force: 1.0-5.0kgf
 2. Swivel torque force (up): 0.36-4.5N.cm
 3. Up/Down screw override: >5.0N.cm
 4. Pull force body-tip: >3.5kgf
 5. Drop test: 30" [0.76m] drop onto hard surface, no parts broken
 6. Airtight test (-0.055Mpa keep 5 minute): no leaking
 7. Cup pushback force: >1.5kgf

Estimated Capacity: 1.5ml

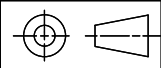
6	change specification	WX	2019/6/12							
5	change body&tip	WX	2019/5/21							
4	Change TIP&CUP	WX	2019/4/11	CUSTOMER						
3	Change the base shape	WX	2019/3/22	PART	P17-356A assembly					
2	51.95->53.05; 53.06->54.16;	WX	2019/3/20	NAME	CYLINDRICAL	DESIGN	WYF	DATE	2019/03/05	
1	5.43±0.1 -> 6.43±0.1 53.05->51.95 54.34->53.06	WYF	19/03/04	CODE	PP2020019	CHECKED		APPROVED		
NO.	REVISIONS DESCRIPTION	DRAWN	DATE	SCALE	1: 1		PLATE	A4	MATERIAL	--
*Dim. are adjustable based on functional requirement		TOL.	±0.1mm	UNIT	mm [in]	DRAWING NO.	----	REV	00	