

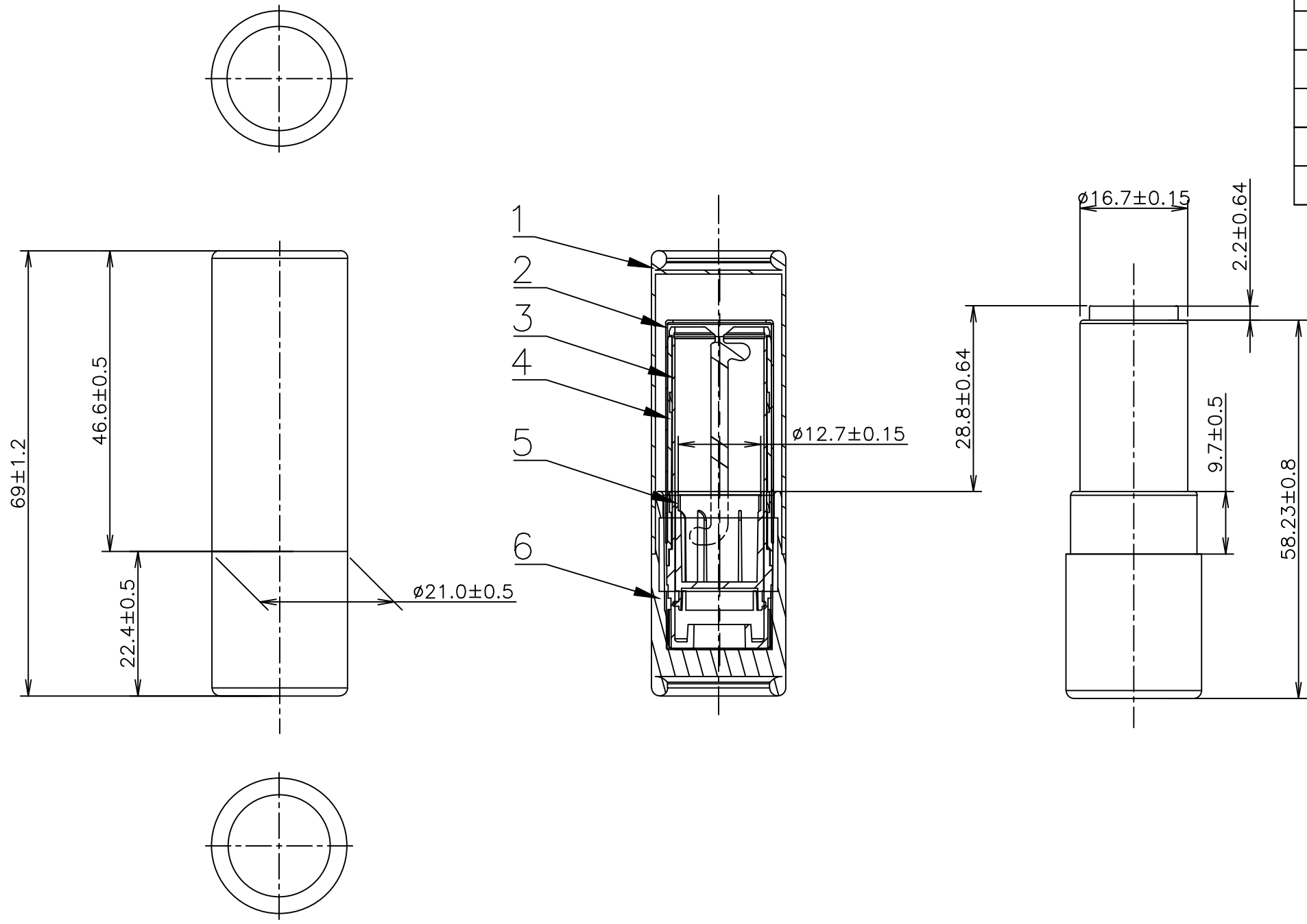
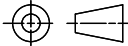

| No. | NAME | Material | Drawing No. |
|-----|------------|----------|-------------|
| 1 | CAP | PAPER | --- |
| 2 | A-SHELL | AL | --- |
| 3 | INNER BODY | PS | --- |
| 4 | SPRIAL | PS | --- |
| 5 | CUP | POM | --- |
| 6 | BASE | PAPER | --- |



PL2020006-Paper

| | | | | | | | | | | |
|--|-----------------------|-------|--------|----------|----------|---|-------|----------|----------|--------|
| 4 | | | | CUSTOMER | |  | | | | |
| 3 | | | | PART | ASSEMBLY | | | | | |
| 2 | | | | NAME | LIPSTICK | | | | | DESIGN |
| 1 | | | | CODE | | CHECKED | | APPROVED | | |
| NO. | REVISIONS DESCRIPTION | DRAWN | DATE | SCALE | 1: 1 |  | PLATE | A4 | MATERIAL | -- |
| *Dim. are adjustable based on functional requirement | | TOL. | ±0.1mm | UNIT | mm [in] | DRAWING NO. | --- | REV | 00 | |