

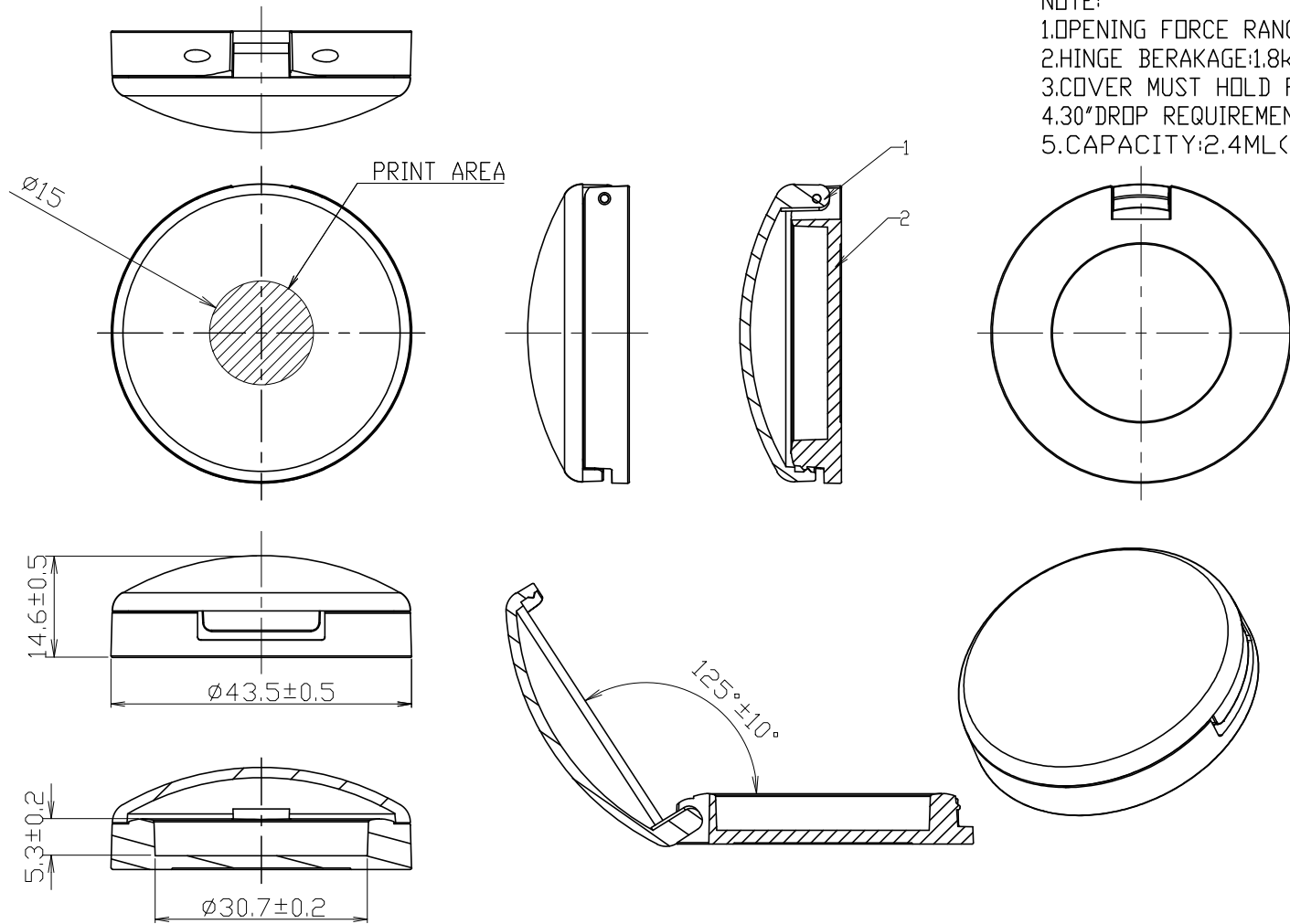

2		BASE	D16110	ABS
1		COVER	D16109	AS
No.	Qty	Part name	Part code	Material

NOTE:

- 1.OPENING FORCE RANGE:0.1kgf~1.0kgf
- 2.HINGE BERAKAGE:1.8kgf min
- 3.COVER MUST HOLD POSITION AT ANY ANGLE
- 4.30°DROP REQUIREMENT: NO BREAKAGE
- 5.CAPACITY:2.4ML(AL PAN)



PC2020012

D4				CUSTOMER	DDRIA				
D3				PART	ASSEMBLY				
D2				NAME	DC007D-ASM	DESIGN	BERNIE	DATE	20161121
D1				CODE	DC007D	CHECKED		APPROVED	
NO.	REVISIONS DESCRIPTION	DRAWN	DATE	SCALE	1:1		PLATE	A4	MATERIAL
*Dim. are adjustable based on functional requirement		TOL.	---	UNIT	mm[in]	DRAWING NO.	D16108	REV	00